

USER FRIENDLY

A
B
C
D
E
F
G
H
I
J
K



K 500
BTV Manual

Bottom Tank Valves
with Manual Actuators
and Diaphragms



K 505
BTV Pneumatic

Bottom Tank Valves
with NC Pneumatic
Actuators and Diaphragms



K 510
BTV Pneumatic with sensors

Bottom Tank Valves
with NC Pneumatic
Actuators, Diaphragms
and Position Sensors

TECHNICAL INFORMATION _ **YBTV A0## #### 1 ## #**

BTV MANUAL

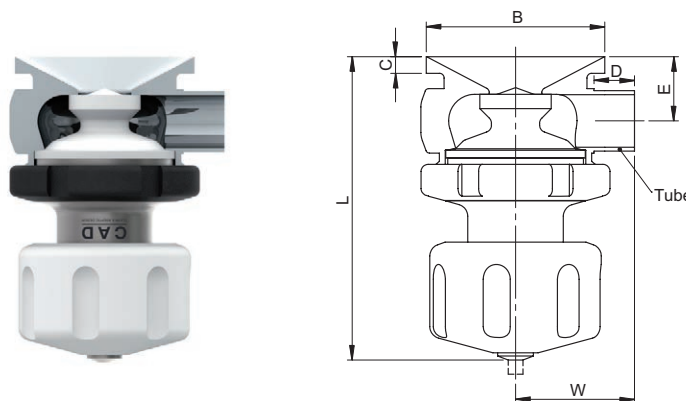

YBTV A0## #### 1 ## # - BOTTOM TANK VALVES WITH MANUAL ACTUATORS AND DIAPHRAGMS are designed to take off fluids from the tank bottom for most stringent applications such as bioreactors, fermenters and preparation tanks. The body shape and their internal design offer a very reliable component for Aseptic Processing Applications. They have a simple and safe design, with full drainability, without asymptotic seals and dead legs, offering fast cleanability and sterilization practices. They are designed to fulfill the most stringent demands of CIP-SIP and production activities in Aseptic Processing. Equipped with PTFE diaphragms acc. to USP Class VI-121°C, or EPDM USP Class VI or Silicone USP Class VI, Manual Actuators made from stainless steel and PTFE. Bottom tank valves (BTV) are available in 6 different designs and 3 different outlet configurations to fulfill customer needs: with short butt weld ends, 45°, TC, with or without satellite valve for downstream CIP-SIP for clean and sterile transfer.

CODE	CAD Size	B mm	C mm	D mm	E mm	W mm	Tube mm	L mm	T (*) C°	P bar
YBTV A012 #### 1 ## #	A12	40.00	6.50	13.00	18.50	30.00	12.70x1.65	90.50	-80 / 200	-1 / 6
YBTV A019 #### 1 ## #	A19	55.00	7.00	16.00	21.70	40.00	19.05x1.65	102.00	-80 / 200	-1 / 6
YBTV A025 #### 1 ## #	A25	75.00	7.00	17.00	27.00	50.00	25.40x1.65	128.00	-80 / 200	-1 / 6
YBTV A038 #### 1 ## #	A38	85.00	7.00	18.50	34.50	60.00	38.10x1.65	159.00	-80 / 200	-1 / 6
YBTV A050 #### 1 ## #	A50	110.00	7.00	24.00	40.00	75.00	50.80x1.65	185.00	-80 / 200	-1 / 6

All dimensions are in mm - All data may change without prior notice
 (*) For PTFE only

Body material: 1.4435-BN2 - Low Ferrite - Low Sulphur

Diaphragm material: PTFE USP Class VI – 121°C or EPDM USP Class VI or Silicone USP Class VI

Application Areas: SAFE

Surface Roughness: Internal surface (manually polished)
 Ra ≤ 0.3µm (16µin)

External surface: Ra ≤ 0.8µm (32µin)

Surface Treatment: Manually polished (available also in EP version - Electropolishing after manual polishing)

Labeling: Each valve body is labeled for full LOT traceability

Packaging: Valve body is sealed in plastic bags and packaged in a closed box

Standard Documentation: Operating and Maintenance bulletin, Certificate of Conformity and Materials Certification 3.1

Quality Control: Quality Assurance System guarantees the control and traceability of the product.

Orders and Information: For additional information, drawings or place an order call your nearest distributor.

BODY CONFIGURATIONS

01 # Basic configurations



01 A
Short butt weld outlet

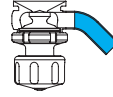

01 B
45° elbow butt weld outlet

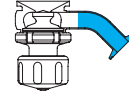

01 C
45° TC outlet

02 # Configurations with SIP Butt Weld Port



02 A
Short butt weld outlet

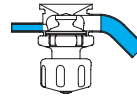

02 B
45° elbow butt weld outlet

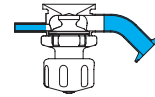

02 C
45° TC outlet

03 # Configurations with SIP TC Port



03 A
Short butt weld outlet

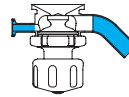

03 B
45° elbow butt weld outlet

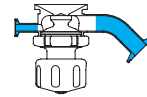

03 C
45° TC outlet

04 # Configurations with Satellite Valve for Sterile Transfer (Downstream CIP/SIP)

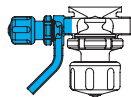

04 A
Short butt weld outlet

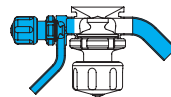

04 B
45° elbow butt weld outlet

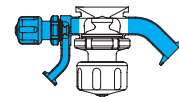

04 C
45° TC outlet

05 # Configurations with Tang. Left Satellite Valve for Sterile Transfer (Downstream CIP/SIP) Space saving design for tight areas

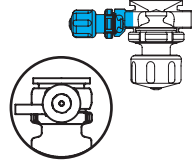

05 A
Short butt weld outlet

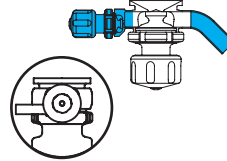

05 B
45° elbow butt weld outlet

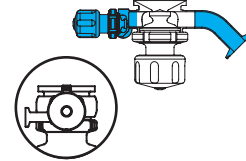

05 C
45° TC outlet

06 # Configurations with Tang. Right Satellite Valve for Sterile Transfer (Downstream CIP/SIP) Space saving design for tight areas

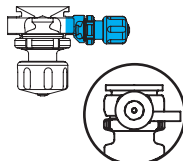

06 A
Short butt weld outlet

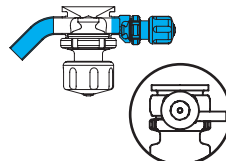

06 B
45° elbow butt weld outlet

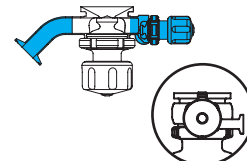

06 C
45° TC outlet

ATTENTION: add the code of the configuration (example: "01 C")
after the code of the valve (instead of: "## #") in order to achieve the complete valve code

TECHNICAL INFORMATION _ **YBTV A0## ##### 2 ## #**

BTV PNEUMATIC

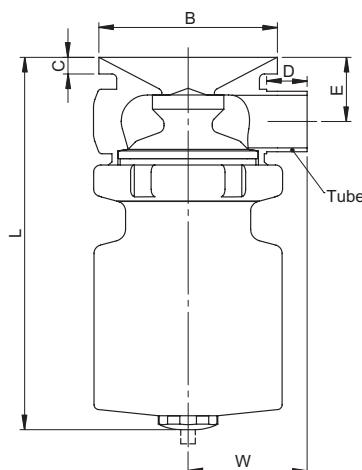

YBTV A0## PTFE 2 ## # - BOTTOM TANK VALVES WITH NC PNEUMATIC ACTUATORS AND DIAPHRAGMS are designed to take off fluids from the tank bottom for most stringent applications such as bioreactors, fermenters and preparation tanks. The body shape and their internal design offer a very reliable component for Aseptic Processing Applications. They have a simple and safe design, with full drainability, without asymptotic seals and dead legs, offering fast cleanability and sterilization practices. They are designed to fulfill the most stringent demands of CIP-SIP and production activities in Aseptic Processing. Equipped with PTFE diaphragms acc. to USP Class VI-121°C, or EPDM USP Class VI or Silicone USP Class VI, NC Pneumatic Actuators made from stainless steel. Bottom tank valves (BTV) are available in 6 different designs and 3 different outlet configurations to fulfill customer needs: with short butt weld ends, 45°, TC, with or without satellite valve for downstream CIP-SIP for clean and sterile transfer.

CODE	CAD Size	B mm	C mm	D mm	E mm	W mm	Tube mm	L mm	T (*) C°	P bar
YBTV A012 ##### 2 ## #	A12	40.00	6.50	13.00	18.50	30.00	12.70x1.65	100.00	-80 / 200	-1 / 6
YBTV A019 ##### 2 ## #	A19	55.00	7.00	16.00	21.70	40.00	19.05x1.65	115.00	-80 / 200	-1 / 6
YBTV A025 ##### 2 ## #	A25	75.00	7.00	17.00	27.00	50.00	25.40x1.65	157.00	-80 / 200	-1 / 6
YBTV A038 ##### 2 ## #	A38	85.00	7.00	18.50	34.50	60.00	38.10x1.65	198.00	-80 / 200	-1 / 6
YBTV A050 ##### 2 ## #	A50	110.00	7.00	24.00	40.00	75.00	50.80x1.65	243.00	-80 / 200	-1 / 6
YBTV A063 ##### 2 ## #	A63	125.00	10.00	24.00	48.00	85.00	63.50x1.65	278.00	-80 / 200	-1 / 6
YBTV A076 ##### 2 ## #	A76	150.00	10.00	30.00	58.00	100.00	76.20x1.65	308.00	-80 / 200	-1 / 4
YBTV A000 ##### 2 ## #	A00	180.00	15.00	30.00	72.50	115.00	101.60x2.11	425.00	-80 / 200	-1 / 4

All dimensions are in mm - All data may change without prior notice
 (*) For PTFE only

Body material: 1.4435-BN2 - Low Ferrite - Low Sulphur

Diaphragm material: PTFE USP Class VI – 121°C or EPDM USP Class VI or Silicone USP Class VI

Application Areas: SAFE

Surface Roughness: Internal surface (manually polished) Ra ≤ 0.3µm (16µin)

External surface: Ra ≤ 0.8µm (32µin)

Surface Treatment: Manually polished (available also in EP version - Electropolishing after manual polishing)

Labeling: Each valve body is labeled for full LOT traceability

Packaging: Valve body is sealed in plastic bags and packaged in a closed box

Standard Documentation: Operating and Maintenance bulletin, Certificate of Conformity and Materials Certification 3.1

Quality Control: Quality Assurance System guarantees the control and traceability of the product.

Orders and Information: For additional information, drawings or place an order call your nearest distributor.

BODY CONFIGURATIONS

01 # Basic configurations

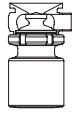

01 A
Short butt weld outlet

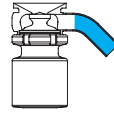

01 B
45° elbow butt weld outlet

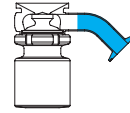

01 C
45° TC outlet

02 # Configurations with SIP Butt Weld Port

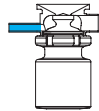

02 A
Short butt weld outlet

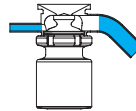

02 B
45° elbow butt weld outlet

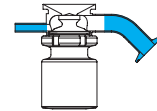

02 C
45° TC outlet

03 # Configurations with SIP TC Port

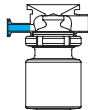

03 A
Short butt weld outlet

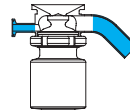

03 B
45° elbow butt weld outlet

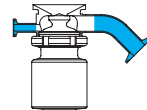

03 C
45° TC outlet

04 # Configurations with Satellite Valve for Sterile Transfer (Downstream CIP/SIP)

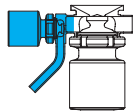

04 A
Short butt weld outlet

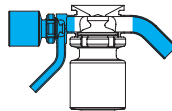

04 B
45° elbow butt weld outlet

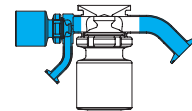

04 C
45° TC outlet

05 # Configurations with Tang. Left Satellite Valve for Sterile Transfer (Downstream CIP/SIP) Space saving design for tight areas

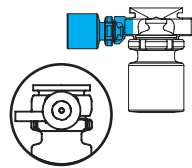

05 A
Short butt weld outlet

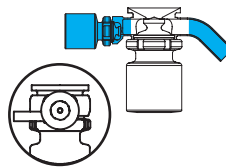

05 B
45° elbow butt weld outlet

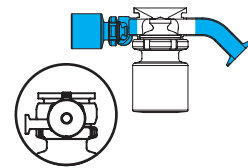

05 C
45° TC outlet

06 # Configurations with Tang. Right Satellite Valve for Sterile Transfer (Downstream CIP/SIP) Space saving design for tight areas

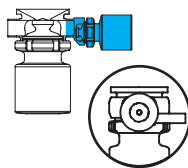

06 A
Short butt weld outlet

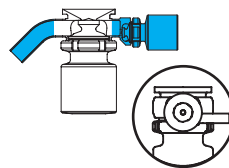

06 B
45° elbow butt weld outlet

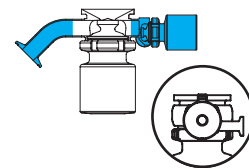

06 C
45° TC outlet

ATTENTION: add the code of the configuration (example: "01 C")
after the code of the valve (instead of: "## #") in order to achieve the complete valve code

TECHNICAL INFORMATION _ YBTV A0## #### 3 ## #

BTV PNEUMATIC WITH SENSORS

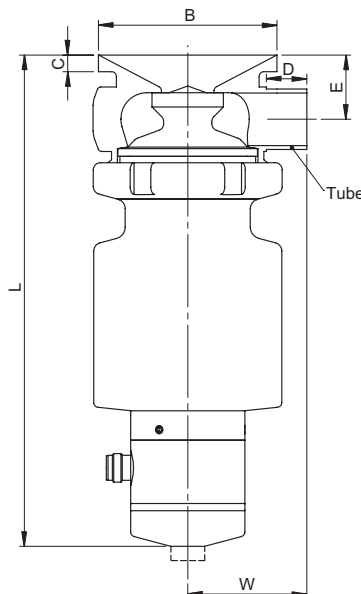

YBTV A0## #### 3 ## # - BOTTOM TANK VALVES WITH NC PNEUMATIC ACTUATORS, DIAPHRAGMS AND POSITION SENSORS are designed to take off fluids from the tank bottom for most stringent applications such as bioreactors, fermenters and preparation tanks. The body shape and their internal design offer a very reliable component for Aseptic Processing Applications. They have a simple and safe design, with full drainability, without asymptotic seals and dead legs, offering fast cleanability and sterilization practices. They are designed to fulfill stringent demands of CIP-SIP and production activities in Aseptic Processing. Equipped with PTFE diaphragms acc. to USP Class VI-121°C or EPDM USP Class VI or Silicone USP Class VI, NC Pneumatic Actuators and CAD Programmable Double Position Sensor made from stainless steel. Bottom tank valves (BTV) are available in 6 different designs and 3 different outlet configurations to fulfill customer needs: with short butt weld ends, 45°, TC, with or without satellite valve for downstream CIP-SIP for clean and sterile transfer.

CODE	CAD Size	B mm	C mm	D mm	E mm	W mm	Tube mm	L mm	T (*) C°	P bar
YBTV A012 #### 3 ## #	A12	40.00	6.50	13.00	18.50	30.00	12.70x1.65	150.00	-80 / 200	-1 / 6
YBTV A019 #### 3 ## #	A19	55.00	7.00	16.00	21.70	40.00	19.05x1.65	165.00	-80 / 200	-1 / 6
YBTV A025 #### 3 ## #	A25	75.00	7.00	17.00	27.00	50.00	25.40x1.65	207.00	-80 / 200	-1 / 6
YBTV A038 #### 3 ## #	A38	85.00	7.00	18.50	34.50	60.00	38.10x1.65	248.00	-80 / 200	-1 / 6
YBTV A050 #### 3 ## #	A50	110.00	7.00	24.00	40.00	75.00	50.80x1.65	293.00	-80 / 200	-1 / 6
YBTV A063 #### 3 ## #	A63	125.00	10.00	24.00	48.00	85.00	63.50x1.65	328.00	-80 / 200	-1 / 6
YBTV A076 #### 3 ## #	A76	150.00	10.00	30.00	58.00	100.00	76.20x1.65	358.00	-80 / 200	-1 / 4
YBTV A000 #### 3 ## #	A00	180.00	15.00	30.00	72.50	115.00	101.60x2.11	475.00	-80 / 200	-1 / 4

All dimensions are in mm - All data may change without prior notice
(*) For PTFE only

Body material: 1.4435-BN2 - Low Ferrite - Low Sulphur

Diaphragm material: PTFE USP Class VI – 121°C or EPDM USP Class VI or Silicone USP Class VI

Application Areas: SAFE

Surface Roughness: Internal surface (manually polished)
Ra ≤ 0.3µm (16µin)

External surface: Ra ≤ 0.8µm (32µin)

Surface Treatment: Manually polished (available also in EP version - Electropolishing after manual polishing)

Labeling: Each valve body is labeled for full LOT traceability

Packaging: Valve body is sealed in plastic bags and packaged in a closed box

Standard Documentation: Operating and Maintenance bulletin, Certificate of Conformity and Materials Certification 3.1

Quality Control: Quality Assurance System guarantees the control and traceability of the product.

Orders and Information: For additional information, drawings or place an order call your nearest distributor.

BODY CONFIGURATIONS

01 # Basic configurations

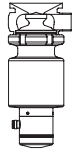

01 A
Short butt weld outlet

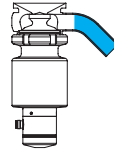

01 B
45° elbow butt weld outlet

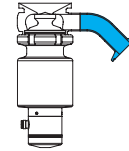

01 C
45° TC outlet

02 # Configurations with SIP Butt Weld Port

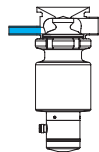

02 A
Short butt weld outlet

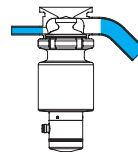

02 B
45° elbow butt weld outlet

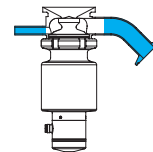

02 C
45° TC outlet

03 # Configurations with SIP TC Port

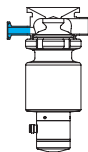

03 A
Short butt weld outlet

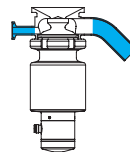

03 B
45° elbow butt weld outlet

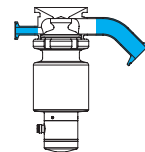

03 C
45° TC outlet

04 # Configurations with Satellite Valve for Sterile Transfer (Downstream CIP/SIP)

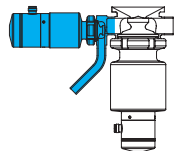

04 A
Short butt weld outlet

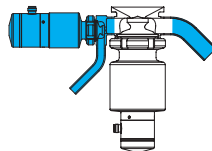

04 B
45° elbow butt weld outlet

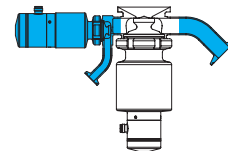

04 C
45° TC outlet

05 # Configurations with Tang. Left Satellite Valve for Sterile Transfer (Downstream CIP/SIP) Space saving design for tight areas

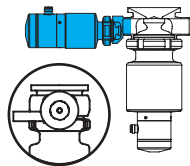

05 A
Short butt weld outlet

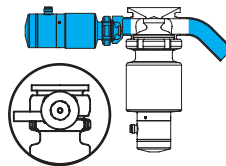

05 B
45° elbow butt weld outlet

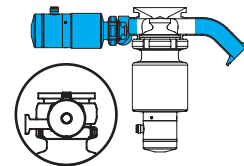

05 C
45° TC outlet

06 # Configurations with Tang. Right Satellite Valve for Sterile Transfer (Downstream CIP/SIP) Space saving design for tight areas

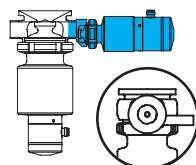

06 A
Short butt weld outlet

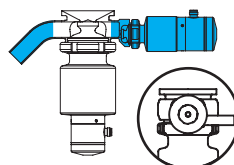

06 B
45° elbow butt weld outlet

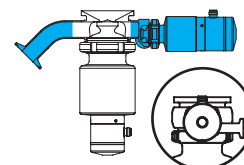

06 C
45° TC outlet

ATTENTION: add the code of the configuration (example: "01 C")
after the code of the valve (instead of: "## #") in order to achieve the complete valve code